

MATERIAL	SIDE RELIEF	END RELIEF	SIDE RAKE
ALUMINUM	12	8	15
BRASS	10	8	5
MILD STEEL	10	8	15
TOOL STEEL	10	8	12-18
STAINLESS	10	8	15-20
CAST IRON	10	8	12

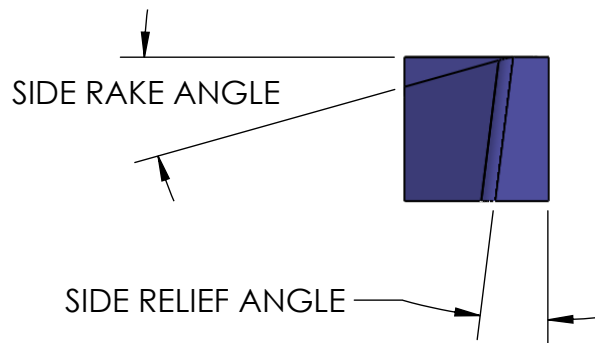
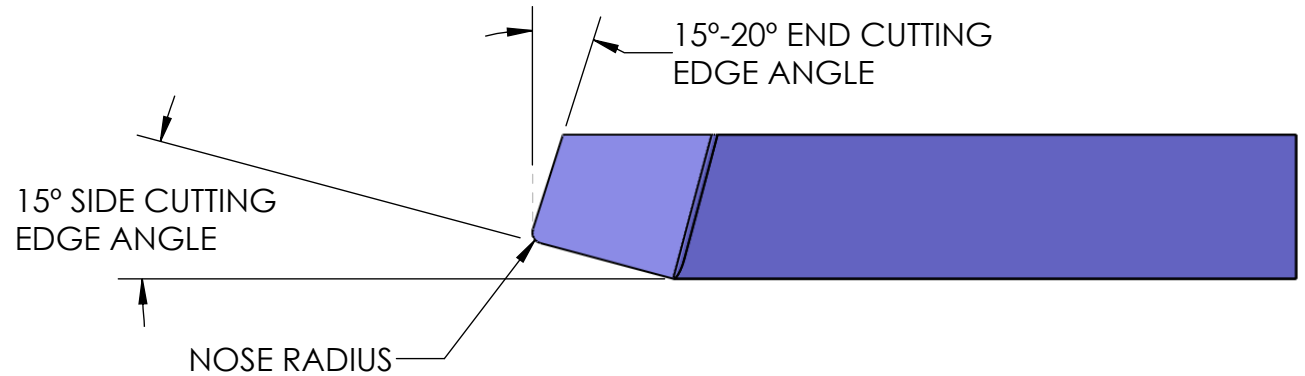

**Tom's Techniques**  
COMMON SENSE MACHINING

UNLESS OTHERWISE SPECIFIED:

DIMENSIONS ARE IN INCHES  
TOLERANCES:  
FRACTIONAL  $\pm 1/32$   
ANGULAR: MACH  $\pm 1/2^\circ$  BEND  $\pm 1^\circ$   
TWO PLACE DECIMAL  $\pm .015$   
THREE PLACE DECIMAL  $\pm .005$

DO NOT SCALE DRAWING

DRAWN  
REVISED  
MATERIAL  
FINISH  
QUANTITY

NAME  
TG  
DATE  
10/31/13

PART NAME

RIGHT HAND TURNING TOOL

SIZE  
**A**

Copyright 2013 Tom Griffin | All Rights Reserved

SCALE: 2:1

SHEET 1 OF 1

REV  
**A**

5

4  
12

3

2

1